

## 430 Eclipse Push Button Slam Latch

### Features

- Push button latch design with slam bolt on side, the Eclipse® push latch requires only a slight depression of the push button to pop open the door. To latch, simply push the door closed.
- Ideal for electronic enclosures, electrical switching systems, industrial cabinets and vehicular applications. Produced with UV stabilized thermoplastic and stainless steel components, latch is suitable for extreme applications that deal with water including boats, campers, trailers, or outdoor containers
- Easy installation with the use of the mounting bracket and 2 screws, which are provided. No external fasteners required and no weld marks to mar finish
- Eclipse latches can be assembled on finished panels. An oil-resistant flange gasket is also provided
- Key-locking version is furnished with two keys

### Material

- Button and housing are manufactured from high strength UV stabilized thermoplastic
- Metal stampings are 300 Series stainless
- Key cylinder is zinc die cast.

### Notes

- Strikers (ECL-19 / ECL-20) also available as separate orders
- For stainless steel key cylinder with dust shutter, part no. is **2EC-430-KP8**

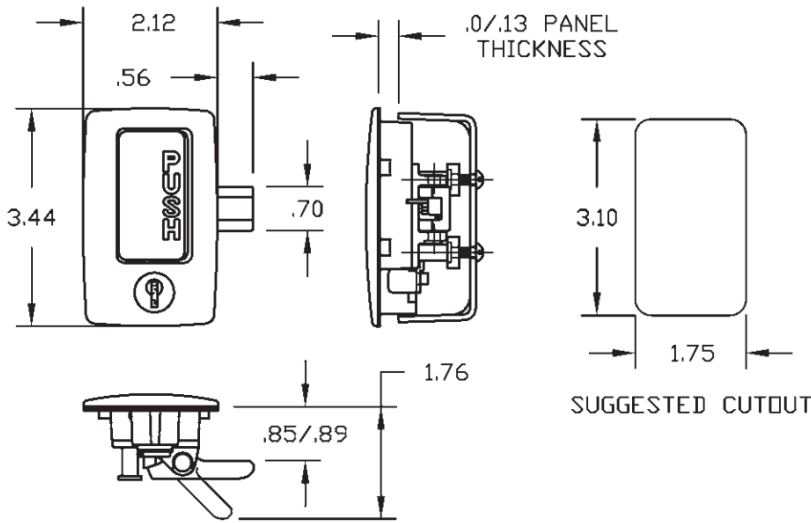

### ECL-19 Striker

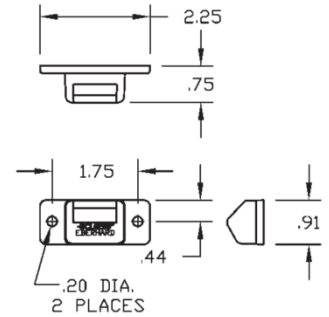

### ECL-20 Striker

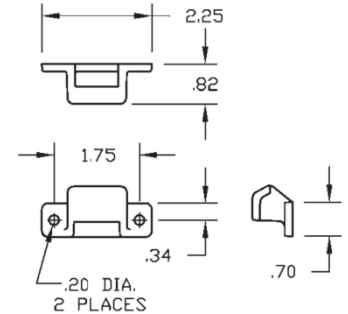

Part No.	Type	Finish
ECL-430-P8-MB	Non-Locking	Matt Black
ECL-430-P8-MW		Matt White
ECL-430-KP8-MB	Key Locking	Matt Black
ECL-430-KP8-MW		Matt White

Dimensions in inches



We are Eberhard's exclusive distributor